



128K x 8 Static RAM

Features

- 4.5V–5.5V operation
- CMOS for optimum speed/power
- Low active power (70 ns, LL version)
 - 82.5 mW (max.) (15 mA)
- Low standby power (70 ns, LL version)
 - 110 μW (max.) (15 μA)
- Automatic power-down when deselected
- TTL-compatible inputs and outputs
- Easy memory expansion with \overline{CE}_1 , CE_2 , and \overline{OE} options

Functional Description

The CY62128B is a high-performance CMOS static RAM organized as 131,072 words by 8 bits. Easy memory expansion is provided by an active LOW Chip Enable (\overline{CE}_1), an active HIGH Chip Enable (CE_2), an active LOW Output Enable (\overline{OE}),

and three-state drivers. This device has an automatic power-down feature that reduces power consumption by more than 75% when deselected.

Writing to the device is accomplished by taking Chip Enable One (\overline{CE}_1) and Write Enable (\overline{WE}) inputs LOW and Chip Enable Two (CE_2) input HIGH. Data on the eight I/O pins (I/O_0 through I/O_7) is then written into the location specified on the address pins (A_0 through A_{16}).

Reading from the device is accomplished by taking Chip Enable One (\overline{CE}_1) and Output Enable (\overline{OE}) LOW while forcing Write Enable (\overline{WE}) and Chip Enable Two (CE_2) HIGH. Under these conditions, the contents of the memory location specified by the address pins will appear on the I/O pins.

The eight input/output pins (I/O_0 through I/O_7) are placed in a high-impedance state when the device is deselected (\overline{CE}_1 HIGH or CE_2 LOW), the outputs are disabled (\overline{OE} HIGH), or during a write operation (\overline{CE}_1 LOW, CE_2 HIGH, and \overline{WE} LOW).

The CY62128B is available in a standard 450-mil-wide SOIC, 32-pin TSOP type I and STSOP packages.

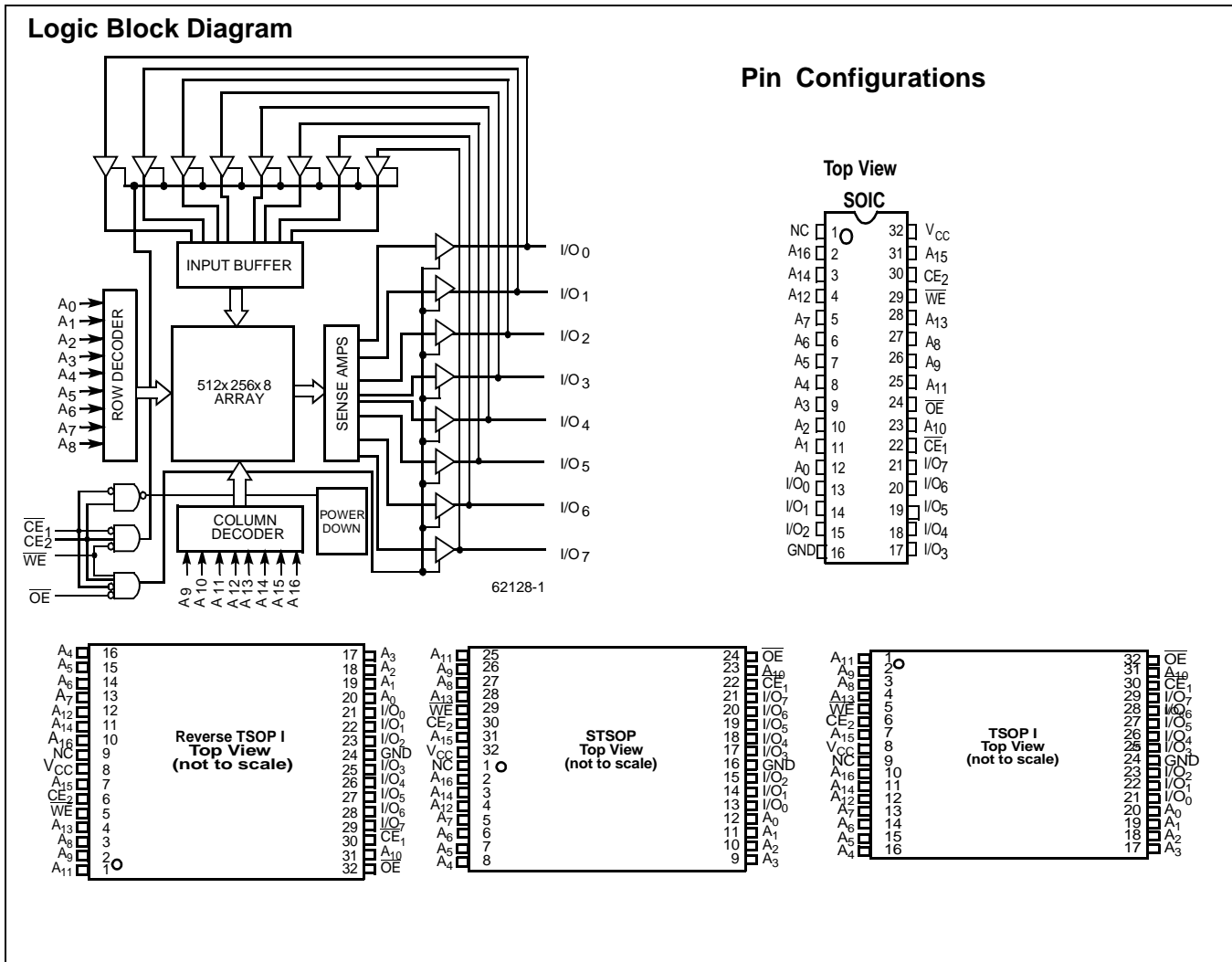

Selection Guide

			CY62128B-55	CY62128B-70	Unit
Maximum Access Time			55	70	ns
Maximum Operating Current (I_{CC})	Industrial	LL	20	15	mA
	Commercial	LL	20	15	mA
Maximum CMOS Standby Current (I_{SB2})	Industrial	LL	15	15	μ A
	Commercial	LL	15	15	μ A

Maximum Ratings

(Above which the useful life may be impaired. For user guidelines, not tested.)

Storage Temperature -65°C to $+150^{\circ}\text{C}$

Ambient Temperature with Power Applied -55°C to $+125^{\circ}\text{C}$

Supply Voltage on V_{CC} to Relative GND^[1] -0.5V to $+7.0\text{V}$

DC Voltage Applied to Outputs in High Z State^[1] -0.5V to $V_{CC} + 0.5\text{V}$

DC Input Voltage^[1] -0.5V to $V_{CC} + 0.5\text{V}$

Current into Outputs (LOW)..... 20 mA

Static Discharge Voltage $>2001\text{V}$
(per MIL-STD-883, Method 3015)

Latch-Up Current..... $>200\text{ mA}$

Operating Range

Range	Ambient Temperature ^[2]	V
Industrial	-40°C to $+85^{\circ}\text{C}$	$5\text{V} \pm 10\%$
Commercial	0°C to $+70^{\circ}\text{C}$	$5\text{V} \pm 10\%$

Notes:

- V_{IL} (min.) = -2.0V for pulse durations of less than 20 ns.
- T_A is the "Instant On" case temperature.

Electrical Characteristics Over the Operating Range

Parameter	Description	Test Conditions	62128B-55			62128B-70			Unit	
			Min.	Typ. ^[3]	Max.	Min.	Typ. ^[3]	Max.		
V _{OH}	Output HIGH Voltage	V _{CC} = Min., I _{OH} = -1.0 mA	2.4			2.4			V	
V _{OL}	Output LOW Voltage	V _{CC} = Min., I _{OL} = 2.1 mA			0.4			0.4	V	
V _{IH}	Input HIGH Voltage		2.2		V _{CC} + 0.3	2.2		V _{CC} + 0.3	V	
V _{IL}	Input LOW Voltage ^[1]		-0.3		0.8	-0.3		0.8	V	
I _{IX}	Input Load Current	GND ≤ V _I ≤ V _{CC}	-1		+1	-1		+1	μA	
I _{OZ}	Output Leakage Current	GND ≤ V _I ≤ V _{CC} , Output Disabled	-1		+1	-1		+1	μA	
I _{OS}	Output Short Circuit Current ^[4]	V _{CC} = Max., V _{OUT} = GND			-300			-300	mA	
I _{CC}	V _{CC} Operating Supply Current	V _{CC} = Max., I _{OUT} = 0 mA, f = f _{MAX} = 1/t _{RC}		Ind'l	LL	7.5	20	6	15	mA
I _{SB1}	Automatic CE Power-Down Current —TTL Inputs	Max. V _{CC} , CE ₁ ≥ V _{IH} or CE ₂ ≤ V _{IL} , V _{IN} ≥ V _{IH} or V _{IN} ≤ V _{IL} , f = f _{MAX}		Ind'l	LL	0.1	2	0.1	1	mA
I _{SB2}	Automatic CE Power-Down Current —CMOS Inputs	Max. V _{CC} , CE ₁ ≥ V _{CC} - 0.3V, or CE ₂ ≤ 0.3V, V _{IN} ≥ V _{CC} - 0.3V, or V _{IN} ≤ 0.3V, f = 0		Ind'l	LL	2.5	15	2.5	15	μA
I _{CC}	V _{CC} Operating Supply Current	V _{CC} = Max., I _{OUT} = 0 mA, f = f _{MAX} = 1/t _{RC}		Com	LL	7.5	20	6	15	mA
I _{SB1}	Automatic CE Power-Down Current —TTL Inputs	Max. V _{CC} , CE ₁ ≥ V _{IH} or CE ₂ ≤ V _{IL} , V _{IN} ≥ V _{IH} or V _{IN} ≤ V _{IL} , f = f _{MAX}		Com	LL	0.1	2	0.1	1	mA
I _{SB2}	Automatic CE Power-Down Current —CMOS Inputs	Max. V _{CC} , CE ₁ ≥ V _{CC} - 0.3V, or CE ₂ ≤ 0.3V, V _{IN} ≥ V _{CC} - 0.3V, or V _{IN} ≤ 0.3V, f = 0		Com	LL	2.5	15	2.5	15	μA

Capacitance^[5]

Parameter	Description	Test Conditions	Max.	Unit
C _{IN}	Input Capacitance	T _A = 25°C, f = 1 MHz, V _{CC} = 5.0V	9	pF
C _{OUT}	Output Capacitance		9	pF

Notes:

- Typical values are included for reference only and are not tested or guaranteed. Typical values are an average of the distribution across normal production variations as measured at V_{CC} = 5.0V, T_A = 25°C, and t_{AA} = 70 ns
- Not more than one output should be shorted at one time. Duration of the short circuit should not exceed 30 seconds.
- Tested initially and after any design or process changes that may affect these parameters.

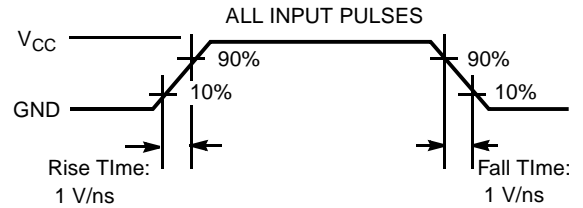
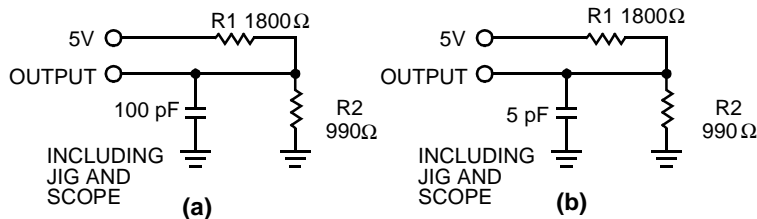
AC Test Loads and Waveforms

Equivalent to: THÉVENIN EQUIVALENT
 OUTPUT $\text{---} \frac{639\Omega}{\text{---}} \text{---} 1.77\text{V}$

Switching Characteristics^[6] Over the Operating Range

Parameter	Description	62128B-55		62128B-70		Unit
		Min.	Max.	Min.	Max.	
READ CYCLE						
t_{RC}	Read Cycle Time	55		70		ns
t_{AA}	Address to Data Valid		55		70	ns
t_{OHA}	Data Hold from Address Change	5		5		ns
t_{ACE}	\overline{CE}_1 LOW to Data Valid, CE_2 HIGH to Data Valid		55		70	ns
t_{DOE}	\overline{OE} LOW to Data Valid		20		35	ns
t_{LZOE}	\overline{OE} LOW to Low Z	0		0		ns
t_{HZOE}	\overline{OE} HIGH to High Z ^[7, 8]		20		25	ns
t_{LZCE}	\overline{CE}_1 LOW to Low Z, CE_2 HIGH to Low Z ^[8]	5		5		ns
t_{HZCE}	\overline{CE}_1 HIGH to High Z, CE_2 LOW to High Z ^[7, 8]		20		25	ns
t_{PU}	\overline{CE}_1 LOW to Power-Up, CE_2 HIGH to Power-Up	0		0		ns
t_{PD}	\overline{CE}_1 HIGH to Power-Down, CE_2 LOW to Power-Down		55		70	ns
WRITE CYCLE^[9]						
t_{WC}	Write Cycle Time	55		70		ns
t_{SCE}	\overline{CE}_1 LOW to Write End, CE_2 HIGH to Write End	45		60		ns
t_{AW}	Address Set-Up to Write End	45		60		ns
t_{HA}	Address Hold from Write End	0		0		ns
t_{SA}	Address Set-Up to Write Start	0		0		ns
t_{PWE}	\overline{WE} Pulse Width	45		50		ns
t_{SD}	Data Set-Up to Write End	25		30		ns
t_{HD}	Data Hold from Write End	0		0		ns
t_{LZWE}	\overline{WE} HIGH to Low Z ^[8]	5		5		ns
t_{HZWE}	\overline{WE} LOW to High Z ^[7, 8]		20		25	ns

Notes:

- Test conditions assume signal transition time of 5 ns or less, timing reference levels of 1.5V, input pulse levels of 0 to 3.0V, and output loading of the specified I_{OL}/I_{OH} and 100-pF load capacitance.
- t_{HZOE} , t_{HZCE} , and t_{HZWE} are specified with a load capacitance of 5 pF as in part (b) of AC Test Loads. Transition is measured ± 500 mV from steady-state voltage.
- At any given temperature and voltage condition, t_{HZCE} is less than t_{LZCE} , t_{HZOE} is less than t_{LZOE} , and t_{HZWE} is less than t_{LZWE} for any given device.
- The internal write time of the memory is defined by the overlap of \overline{CE}_1 LOW, CE_2 HIGH, and \overline{WE} LOW. \overline{CE}_1 and \overline{WE} must be LOW and CE_2 HIGH to initiate a write, and the transition of any of these signals can terminate the write. The input data set-up and hold timing should be referenced to the leading edge of the signal that terminates the write.

Data Retention Characteristics (Over the Operating Range for “LL” version only)

Parameter	Description	Conditions ^[10]		Min.	Typ.	Max.	Unit
V_{DR}	V_{CC} for Data Retention			2.0			V
I_{CCDR}	Data Retention Current	Ind.'l	LL	$V_{CC} = V_{DR} = 3.0V$, $CE \geq V_{CC} - 0.3V$, $V_{IN} \geq V_{CC} - 0.3V$ or, $V_{IN} \leq 0.3V$		15	μA
I_{CCDR}	Data Retention Current	Com.	LL	$V_{CC} = V_{DR} = 3.0V$, $CE \geq V_{CC} - 0.3V$, $V_{IN} \geq V_{CC} - 0.3V$ or, $V_{IN} \leq 0.3V$		15	μA
$t_{CDR}^{[3]}$	Chip Deselect to Data Retention Time			0			ns
$t_R^{[3]}$	Operation Recovery Time			70			ns

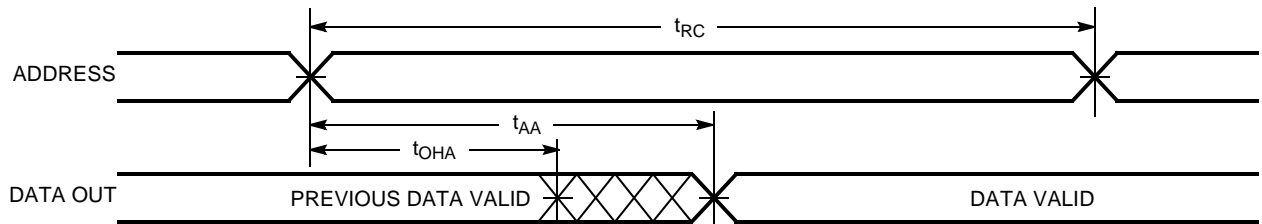
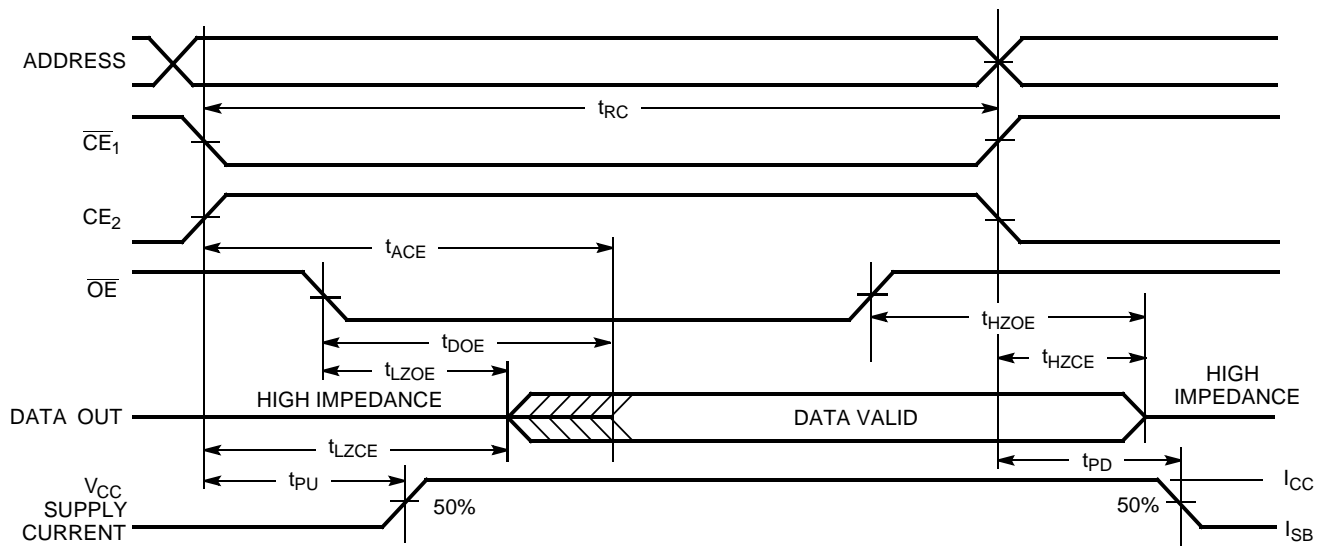
Switching Waveforms
Read Cycle No. 1^[11, 12]

Read Cycle No. 2 (\overline{OE} Controlled)^[12, 13]

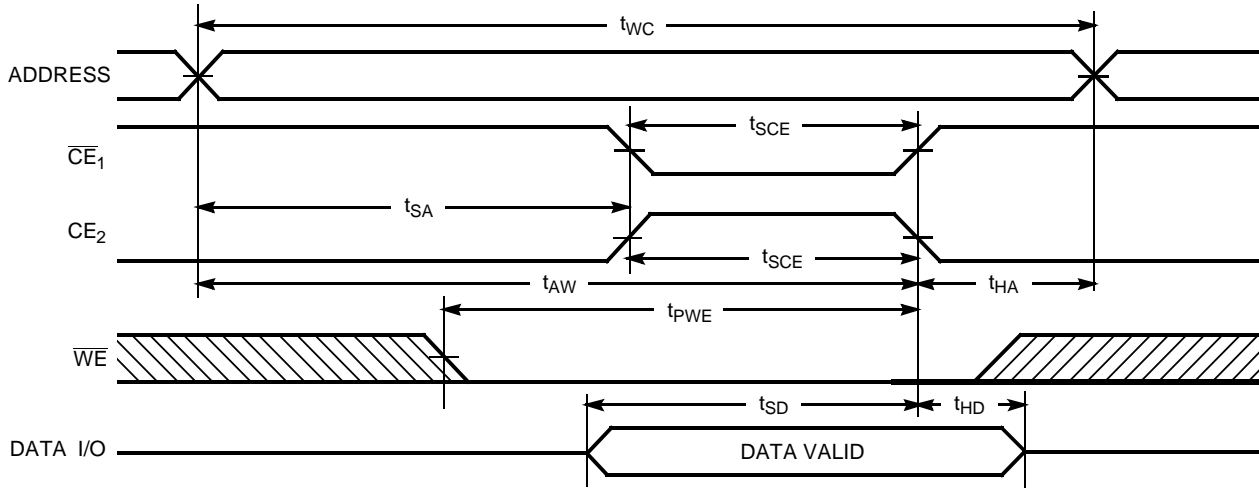
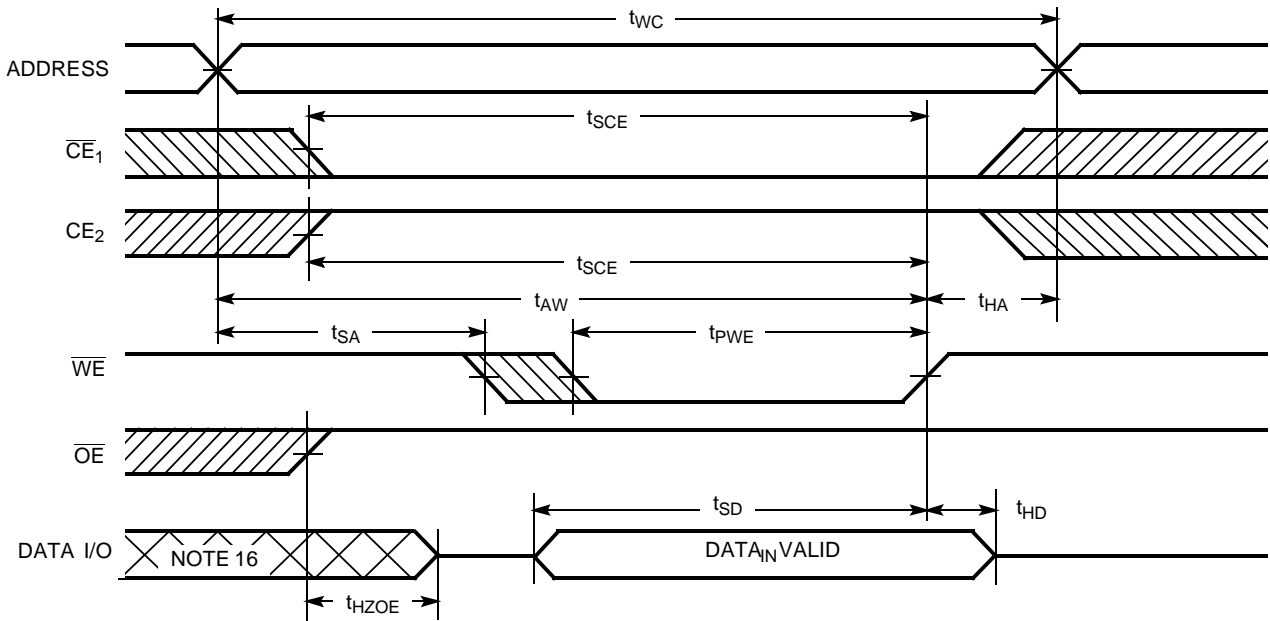
Notes:

10. No input may exceed $V_{CC} + 0.5V$.
11. Device is continuously selected. $\overline{OE}, \overline{CE}_1 = V_{IL}, CE_2 = V_{IH}$.
12. \overline{WE} is HIGH for read cycle.
13. Address valid prior to or coincident with \overline{CE}_1 transition LOW and CE_2 transition HIGH.

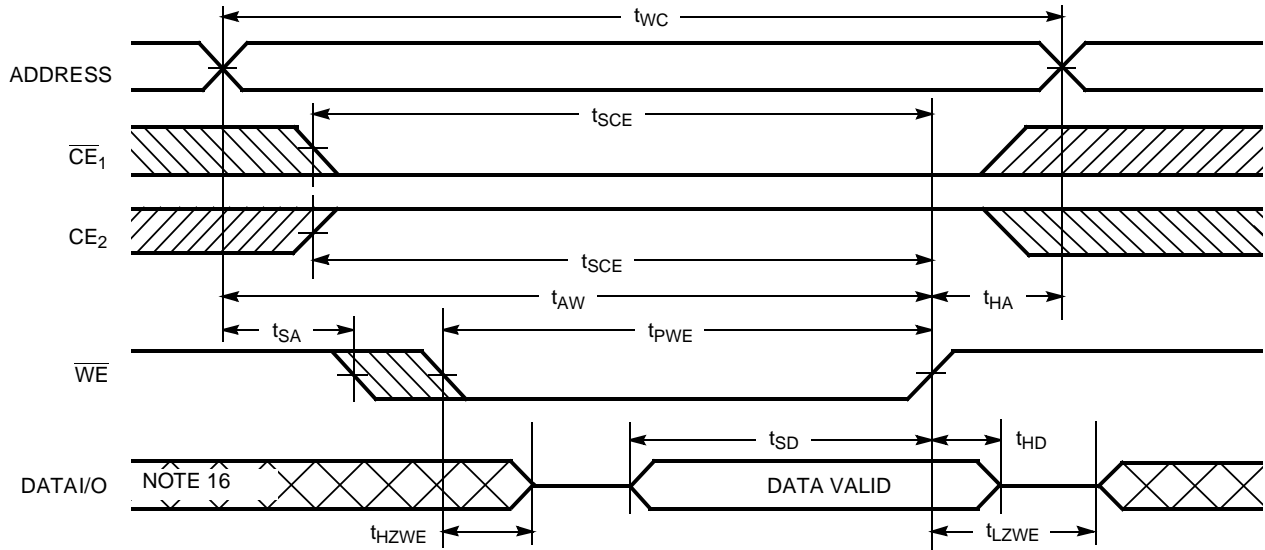
Switching Waveforms (continued)
Write Cycle No. 1 (\overline{CE}_1 or CE_2 Controlled)^[14, 15]

Write Cycle No. 2 (\overline{WE} Controlled, \overline{OE} HIGH During Write)^[14, 15]

Notes:

14. Data I/O is high impedance if $\overline{OE} = V_{IH}$.
15. If \overline{CE}_1 goes HIGH or CE_2 goes LOW simultaneously with \overline{WE} going HIGH, the output remains in a high-impedance state.
16. During this period the I/Os are in the output state and input signals should not be applied..

Switching Waveforms (continued)
Write Cycle No.3 (\overline{WE} Controlled, \overline{OE} LOW)^[14, 15]

Truth Table

\overline{CE}_1	CE_2	\overline{OE}	\overline{WE}	I/O ₀ -I/O ₇	Mode	Power
H	X	X	X	High Z	Power-Down	Standby (I_{SB})
X	L	X	X	High Z	Power-Down	Standby (I_{SB})
L	H	L	H	Data Out	Read	Active (I_{CC})
L	H	X	L	Data In	Write	Active (I_{CC})
L	H	H	H	High Z	Selected, Outputs Disabled	Active (I_{CC})

Ordering Information

Speed (ns)	Ordering Code	Package Name	Package Type	Operating Range
55	CY62128BLL-55SI	S34	32-Lead 450-Mil SOIC	Industrial
	CY62128BLL-55SC	S34	32-Lead 450-Mil SOIC	Commercial
	CY62128BLL-55ZI	Z32	32-Lead TSOP Type I	Industrial
	CY62128BLL-55ZC	Z32	32-Lead TSOP Type I	Commercial
	CY62128BLL-55ZAI	ZA32	32-Lead STSOP Type I	Industrial
	CY62128BLL-55ZAC	ZA32	32-Lead STSOP Type I	Commercial
	CY62128BLL-70ZRI	ZR32	32-Lead Reverse TSOP Type I	Industrial
	CY62128BLL-70ZRC	ZR32	32-Lead Reverse TSOP Type I	Commercial
70	CY62128BLL-70SI	S34	32-Lead 450-Mil SOIC I	Industrial
	CY62128BLL-70SC	S34	32-Lead 450-Mil SOIC I	Commercial
	CY62128BLL-70ZI	Z32	32-Lead TSOP Type I	Industrial
	CY62128BLL-70ZC	Z32	32-Lead TSOP Type I	Commercial
	CY62128BLL-70ZAI	ZA32	32-Lead STSOP Type I	Industrial
	CY62128BLL-70ZAC	ZA32	32-Lead STSOP Type I	Commercial
	CY62128BLL-70ZRI	ZR32	32-Lead Reverse TSOP Type I	Industrial
	CY62128BLL-70ZRC	ZR32	32-Lead Reverse TSOP Type I	Commercial

Document #: 38-00524-*F

Package Diagrams

32-Lead (450 Mil) Molded SOIC S34

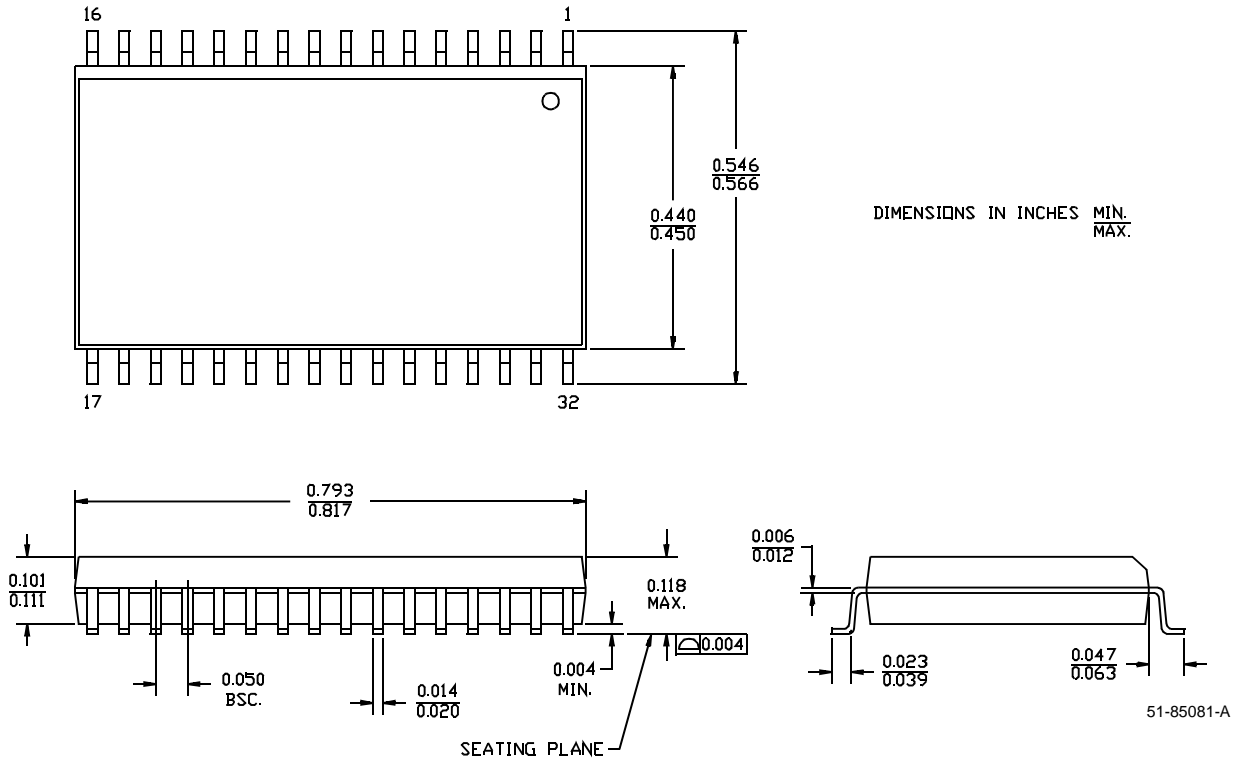

32-Lead (450 Mil) Molded SOIC S34

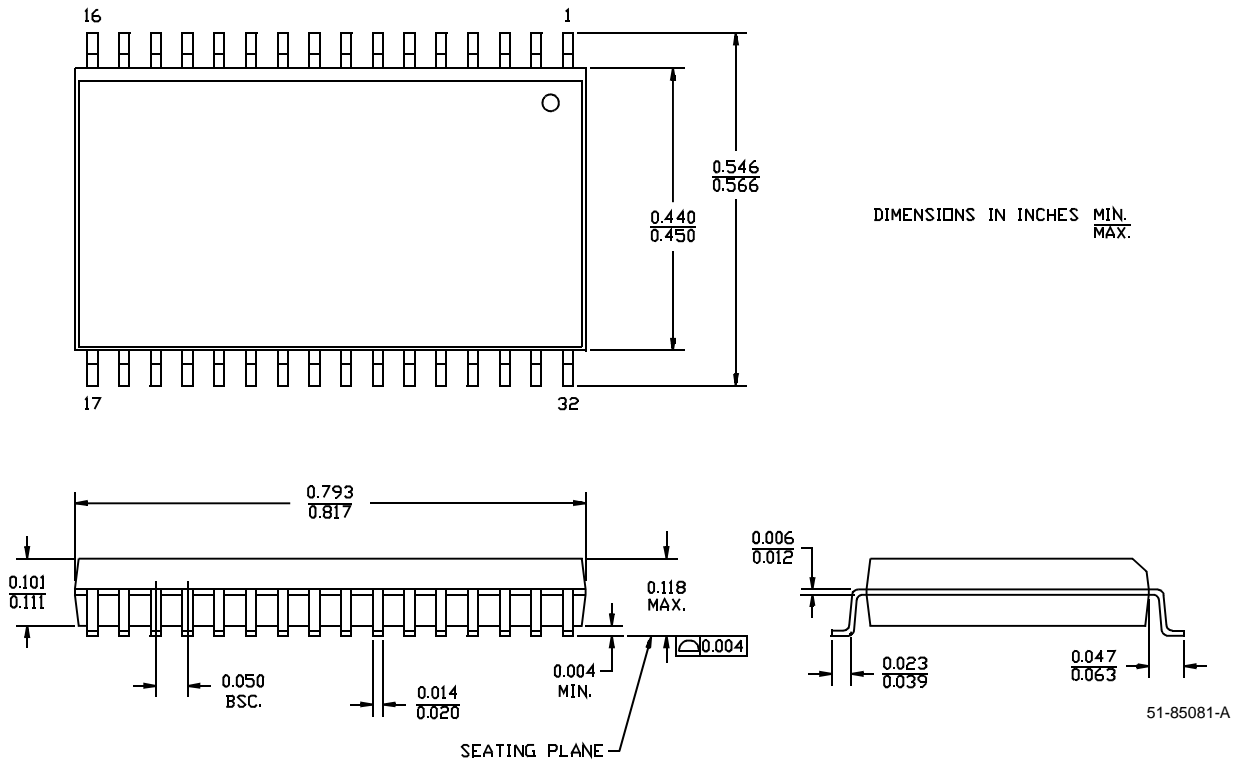

Package Diagrams (continued)

32-Lead Thin Small Outline Package Z32

DIMENSION IN MM
MIN.
MAX.

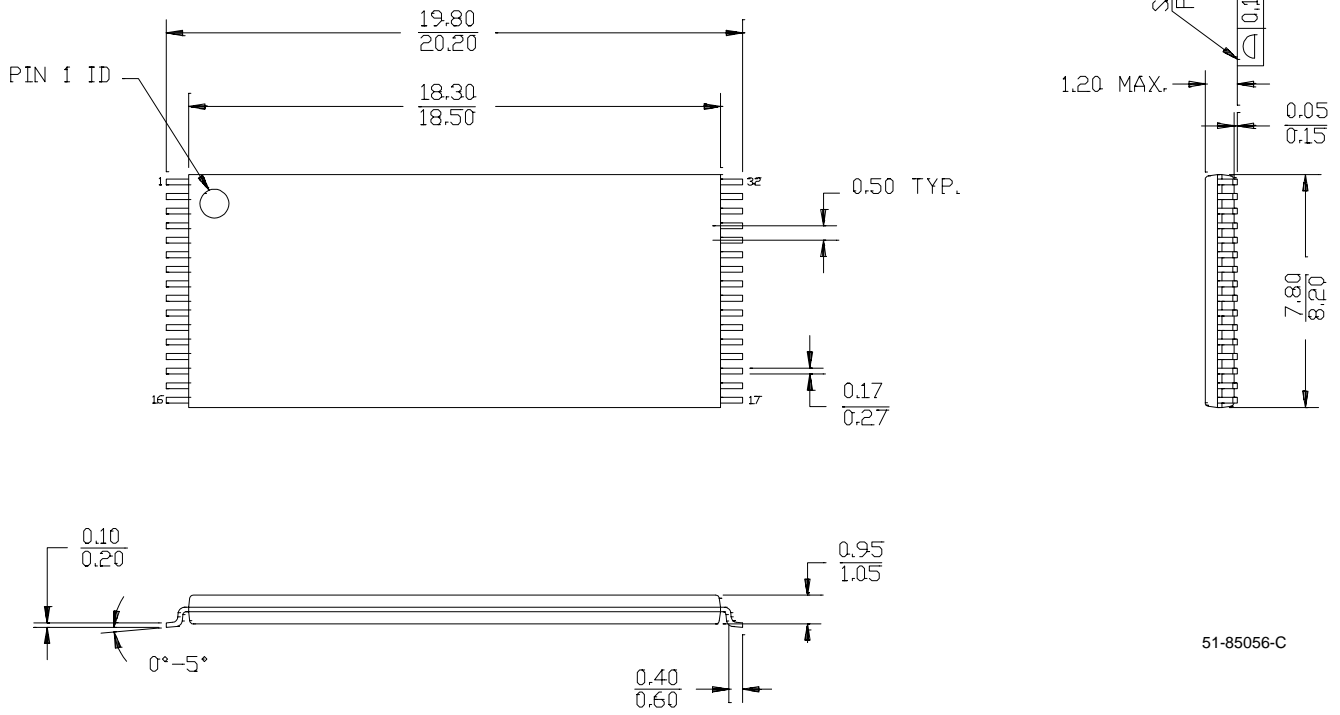

51-85056-C

Package Diagrams (continued)

32-Lead Shrunken Thin Small Outline Package ZA32

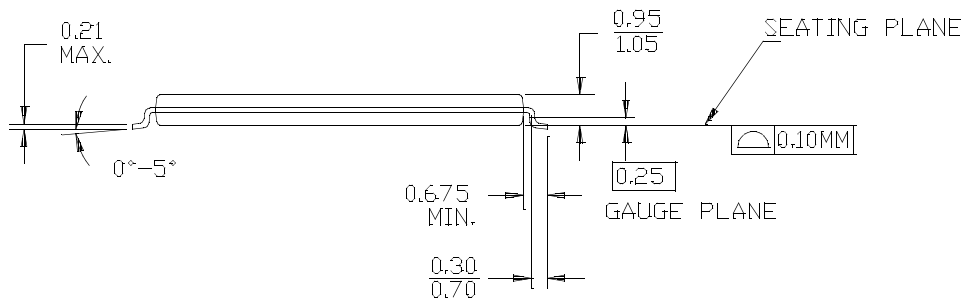
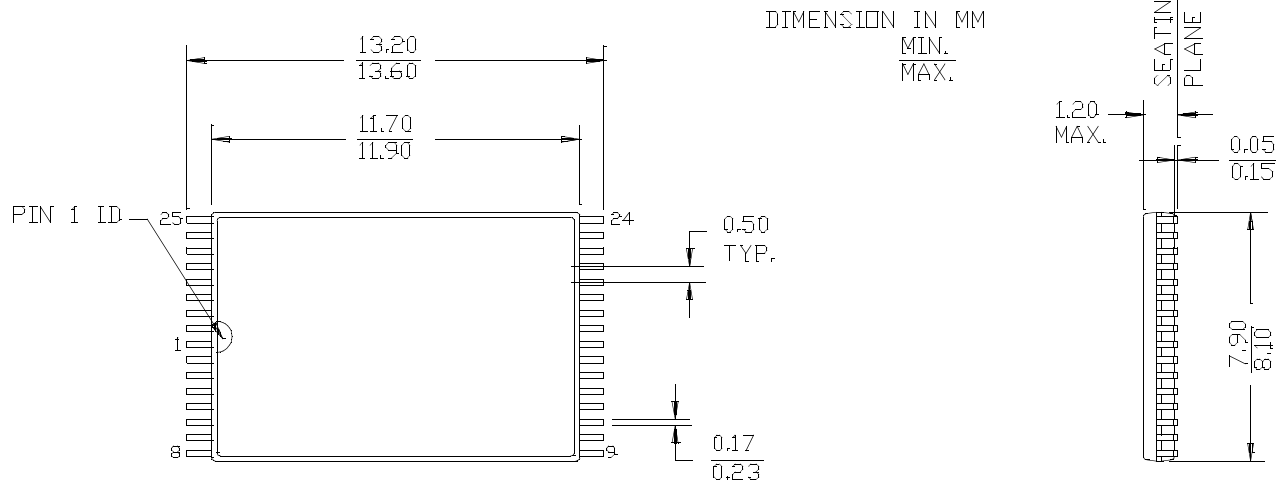

51-85094-B

Package Diagrams (continued)

32-Lead Reverse Thin Small Outline Package ZR32

